

SOLENOID OPERATED CARTRIDGE VALVES

插入式電磁閥

VWE SERIES Spool 4-Way 2-Position VWE 系列閥蕊 四方向 二方位

◆ MODEL 型 式

VWE10-B2

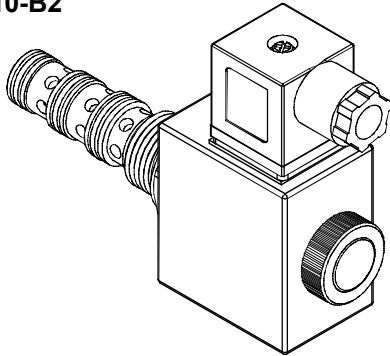

◆ PERFORMANCE 特性曲線

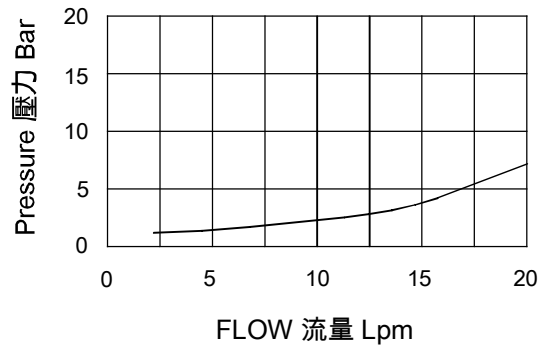

◆ SPECIFICATIONS 規 格

Model Number 型式號碼	Maximum Pressure 最大壓力 bar	Maximum Flow 最大流量 lpm	Weight 重量 Kg
VWE10-B2	210 (3046psi)	20 (5.28gpm)	0.66 (1.46 lbs)
Fluid Type 流體型式		ISO VG 32, 46, 68	
Viscosity 黏性 cSt		10~400 (59~1854 SSU)	
Operating Temperature 操作溫度 °C		-30~100 (-22~212°F)	
Contamination Level 污染標準		ISO4406. 21/19/16 NAS1638,10	

◆ HOW TO ORDER 編號說明

1	2	3	4	5
VWE	10	— B2	— D2	— X

1 VALVE SERIES 系列名稱

VWE= Spool 4-Way 2-Position
閥蕊 四方向 二方位

2 SUBPLATE MOUNTING SIZE 稱呼口徑

Size:10
Cavity 孔口 : CS10-4N
See Page Appendixes-A_004
見附錄A_004 頁面

3 CONTROL PORT(S) 動作形式

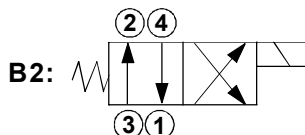

4 TYPE OF COIL 線圈類型

Non : Without Coil 無記號:無線圈

A1 : RAC110V 60/50HZ D1 : DC12V
A2 : RAC220V 60/50HZ D2 : DC24V

5 WIRING TYPE 接線型式

Non: WIRING BOX TYPE (DIN) X : DOUBLE LEAD
無: 接線盒式 (DIN) 雙接線方式



※ For more technical information of wiring type please refer to the appendixes-D or contact with us.
接線型式的詳細技術資料請查附錄-D或與我們聯繫。

◆ DIMENSIONS 外型尺寸圖

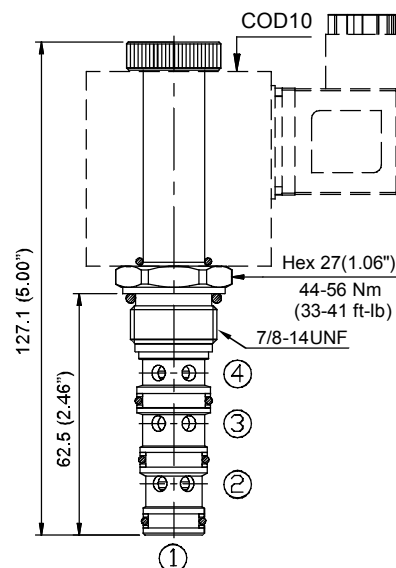

A
012
VWE