

PROPORTIONAL VALVES 比例閥

EVF SERIES PROPORTIONAL FLOW VALVES

EVF 系列比例流量閥

◆ MODEL 型式 EVF-10

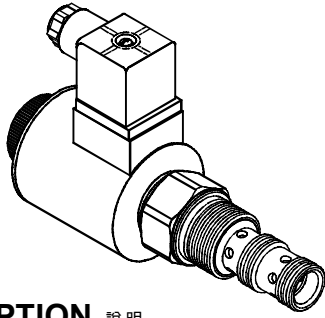

◆ PERFORMANCE 特性曲線

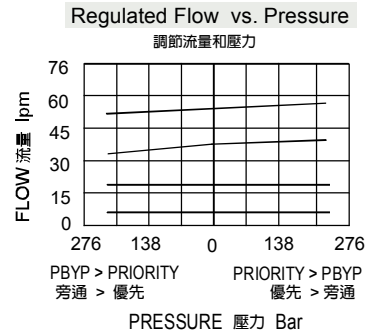
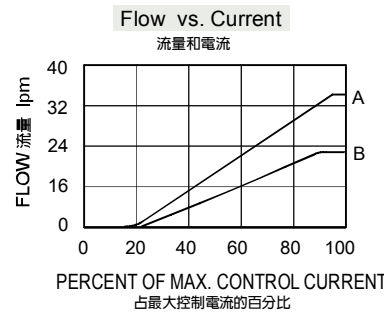

◆ DESCRIPTION 說明

Proportional flow valve. It can be used as a priority-type flow regulator with pressure-compensated, regulated and bypass flow. It can also be used as a restrictive-type 2-way, pressure-compensated flow regulator when the bypass line (port ②) is blocked. 比例流量閥，可以用作帶壓力補償的優先流量調節閥，調節和旁通流量，當封閉旁通線路(油口 ②)時，也可以用作2通節流型壓力補償流量調節閥。

◆ SPECIFICATIONS 規格

Model Number 型式號碼	Operating Pressure 操作壓力 bar	Maximum Flow 最大流量 lpm	Maximum Current 最大電流 mA	Voltage 電壓 VDC	Weight 重量 Kg
EVF-10	240 (3500 psi)	53 (14 gpm)	1500±200 750±100	12 24	0.3 (0.66 lbs)
Fluid Type 流體型式			ISO VG 32, 46, 68		
Viscosity 黏性 cSt			10~400 (59~1854 SSU)		
Operating Temperature 操作溫度 °C			-30~100 (-22~212°F)		
Contamination Level 污染標準			ISO4406. 21/19/16 NAS1638,10		

◆ HOW TO ORDER 編號說明

1	2	3	4	5	6	7
EVF	10	A	NO	D2	*	*

1 VALVE SERIES 系列名稱

EVF = Proportional Flow Valves 比例流量閥

2 SUBPLATE MOUNTING SIZE 稱呼口徑

Size: 10
Cavity 孔口: CS10-3N
See Page Appendixes-A_002
見附錄A_002 頁面

3 REGULATED FLOW RANGE 調節流量範圍

Model 型式	Regulated Flow Rate 調節流量 lpm
A	30 lpm (8 gpm)
B	17 lpm (4.5 gpm)

4 CONTROL PORT(S) 動作形式

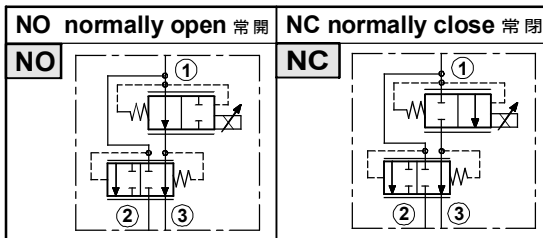

5 TYPE OF COIL 線圈類型

Non: Without Coil 無記號:無線圈
D1: DC12V
D2: DC24V

● TYPE OF COIL 線圈類型
Model number 型式編號: COS12
● Coils must be ordered separately
線圈必須分開訂購

6 ADJUSTMENT OPTION 調整選擇

Non: Standard 無記號:標準型	S: Twist Style Manual Override 旋緊型-手動操作復位	Y: Push Style Manual Override 推壓型-手動操作復位
Non	S	Y

7 SEALS 密封件

Non: NBR (Standard) 無記號:丁腈橡膠(標準型)
HN: HNBR HN: 氫化丁腈橡膠
V: VITON V: 氟橡膠

◆ DIMENSIONS 外型尺寸圖

