

# PROPORTIONAL VALVES 比例閥

## EVGB SERIES PROPORTIONAL REDUCING/RELIEVING VALVES

EVGB 系列比例減泄壓閥

### MODEL 型式

EVGB-E081

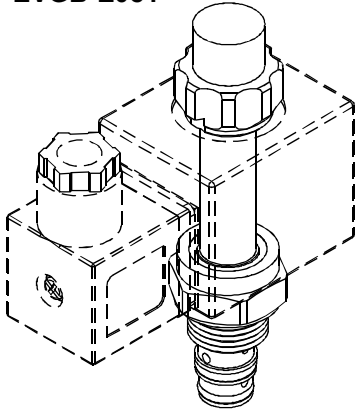

### DESCRIPTION 說明

Direct acting, spool-type reducing/relieving valve, which can be infinitely adjusted across a prescribed range using a variable electric input. Pressure output is proportional to DC current input. This valve is intended for use as a pressure control device in demanding applications.

The EVGB-E081 allows free flow from 1 to 3 when no current is applied to the coil. When the coil is energized, 2 is connected to 1. Increasing current applied to the coil will increase the control (reduced) pressure proportionally. If pressure at 1 exceeds the setting induced by the coil, pressure from 1 is relieved to 3.

直動滑軸式減壓/溢流閥, 利用可變電輸入可實現指定範圍內的連續調節. 輸出壓力與DC電流輸入成比例. 該閥在設備中可用作壓力控制裝置.

線圈中無電流時, EVGB-E081 允許油液從 1 自由流向油口 3. 線圈通電時, 2 將連至 1. 控制(減壓)壓力將隨著線圈中電流的增大而成比例地增大. 如果 1 處的壓力超過線圈的設定壓力, 則在油口 3 溢流.

### PERFORMANCE 特性曲線

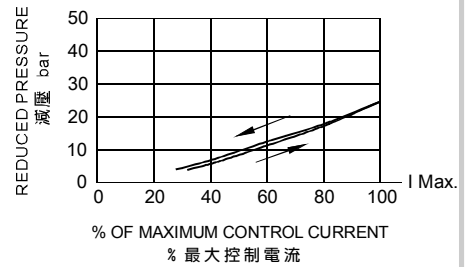
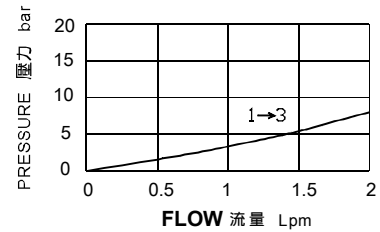

### SPECIFICATIONS 規格

Model Number 型式號碼	Maximum Inlet Pressure In 2 最大入口壓力在2號口 Bar	Reduced Pressure In 1 減壓在1號口 Bar	Rated Flow 額定流量 lpm	Rated Current 額定電流 mA	Voltage 電壓 VDC	Weight 重量 Kg
EVGB-E081	350 (5076 psi)	4-25 (58-363 psi)	2 (0.53 gpm)	1700±10%	12	0.14 (0.31 lbs)
				850±10%	24	
<b>Fluid Type</b> 流體型式				ISO VG 32, 46, 68		
<b>Viscosity</b> 黏性 cSt				10~400 (59~1854 SSU)		
<b>Operating Temperature</b> 操作溫度 °C				-15~70 (-5~158 °F)		
<b>Contamination Level</b> 污染標準				ISO4406. 21/19/16 NAS1638,10		

### HOW TO ORDER 編號說明

<b>1</b>	<b>2</b>
EVGB	E081

#### 1 VALVE SERIES 系列名稱

EVGB=Proportional Reducing/Relieving Valves  
(Direct-Acting) 比例減泄壓閥(直動式)

#### 2 SUBPLATE MOUNTING SIZE 稱呼口徑

E081 : E-081  
Cavity 孔口 : CSE 081-2N

### CONTROL PORT(S) 動作形式

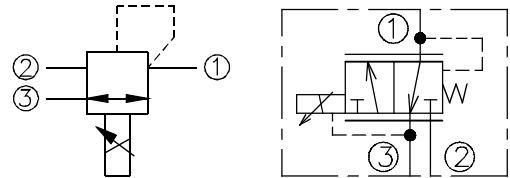

### TYPE OF COIL 線圈類型

Model number 型式編號 : COD08  
See Appendixes-D  
見附錄 D

- Coils must be ordered separately  
線圈必須分開訂購

### DIMENSIONS 外型尺寸圖

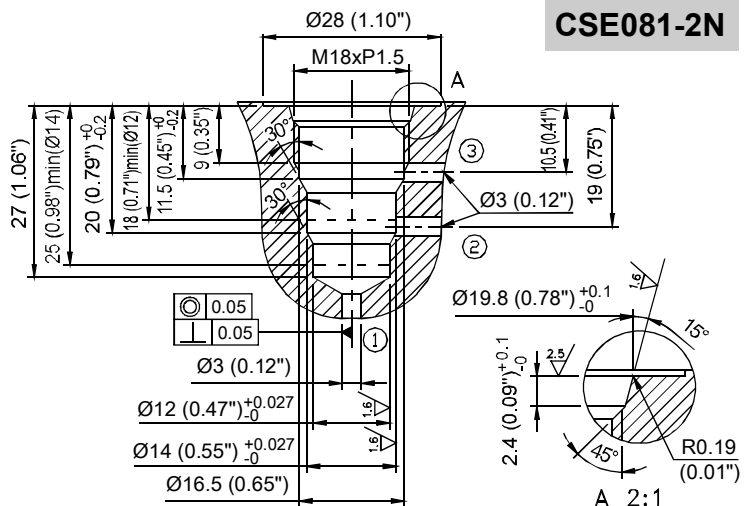
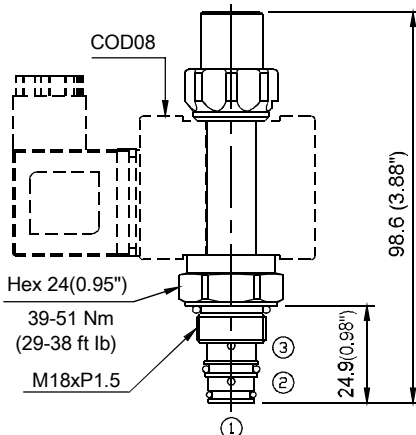

- Allowed Back Pressure at port 3 (T) : 5 bar (73 psi) max.  
允許背壓在孔口 3 (T) : 最大 5bar (73psi)