

◆ FEATURES

- High efficiency, stabilize when high pressure operation.
- Low unpleasant noise, low vibration.
- Instant response for start and stop changing operation.
- Output flow stabilize with high pressure.
- High efficiency operation with low motor power-loss.
- Easy operation for pressure and flow adjustment.

- 特點：
- 高效率、高壓運轉、性能穩定。
- 無振動、低噪音。
- 應答性高，啟動、停止負荷變動，動作靈敏。
- 高壓時，吐油量穩定。
- 馬力損失小，運轉效率高。
- 壓力、流量調整容易，操作簡單。

◆ SPECIFICATIONS 規格

Model 產品型號	Displacement 吐油量 l/min	ADJUSTING PRESSURE RANGE kgf/cm ² 壓力調整範圍	SPEED (rpm) 速度(迴轉數/每分鐘)		MAX. PRESSURE kgf/cm ² 最高設定壓力	WEIGHT 重量 kgf(lbs)
			MAX. (最高)	MIN. (最低)		
VDC-F20※※-10	20	A1 : 15~35 kgf/cm ² (214~500psi) A2 : 20~70 kgf/cm ² (286~1000psi) A3 : 50~105 kgf/cm ² (714~1500psi)	1800	800	140	10(21.9)
VDC-F25※※-10	25					
VDC-F30※※-10	30					
VDC-F40※※-10	40	A4 : 70~140 kgf/cm ² (1000~2000psi)	1800	800	140	25(54.8)
VDC-F54※※-10	54					
VDC-F70※※-10	70					

● Design and specifications are subject to change without prior notice. 本表數據若有變更，恕不另行通知。

◆ HOW TO ORDER 編號說明

1	2	3	4	5
VDC	F	20	**	10

1 MODEL NUMBER 型式號碼

2 MOUNTING 固定方式
F: Flange Type 法蘭型

3 DISPLACEMENT(l/min) 吐油量
See Specifications 參照上表規格

4 PRESSURE ADJUSTMENT 壓力調整範圍
See Specifications 參照上表規格

5 DESIGN NO 設計編號

MEDIUM-PRES. VARIABLE DISPLACEMENT VANE PUMPS

中壓變容量輸泵

PUMPS

◆ DIMENSIONS 外型尺寸圖

VDC-F20 . F25 . F30 . F40

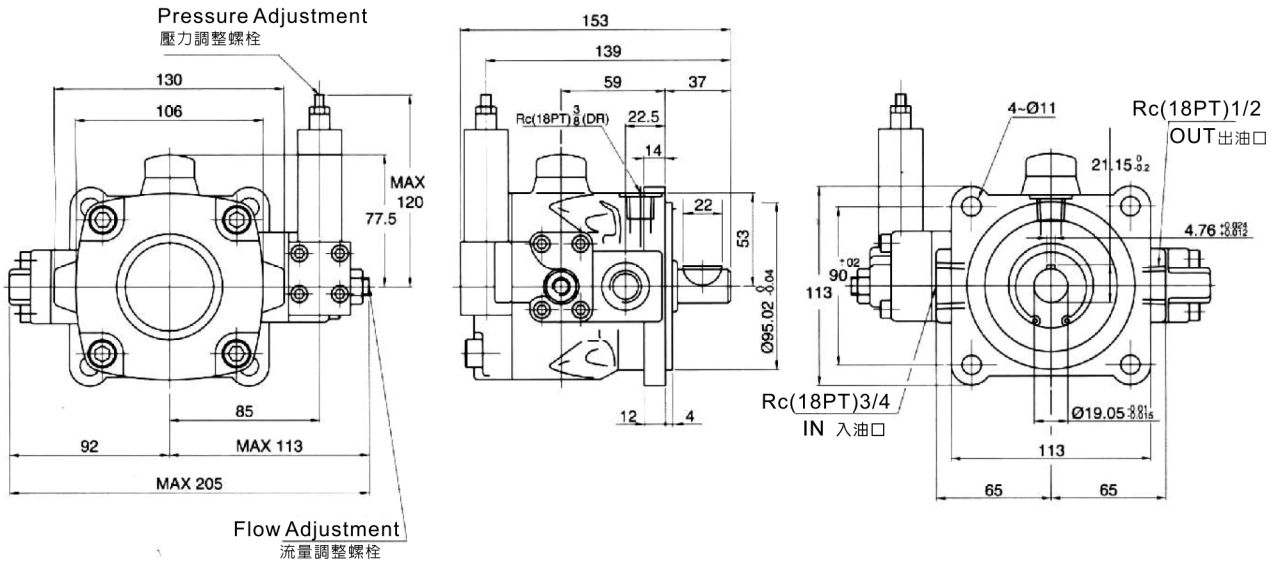

VDC-F20 . F54 . F70

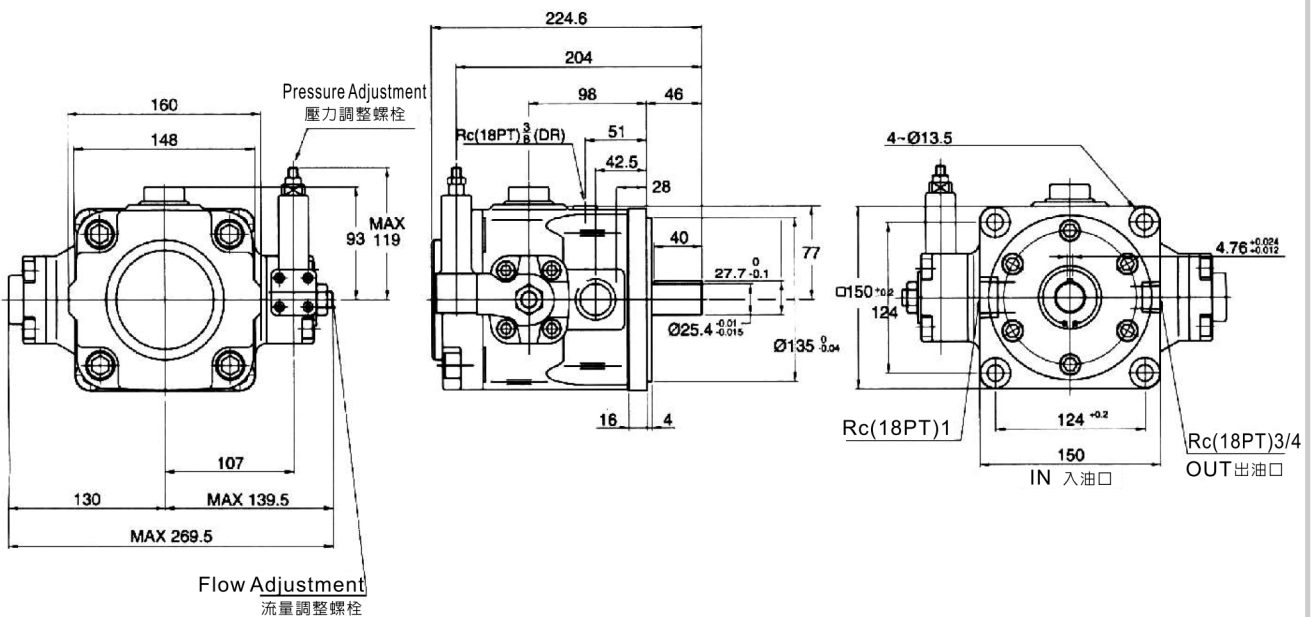

MEDIUM-PRES. VARIABLE DISPLACEMENT VANE PUMPS

中壓變容量輸葉泵

PUMPS

◆ Performance Curves 性能曲線

VDC-F20

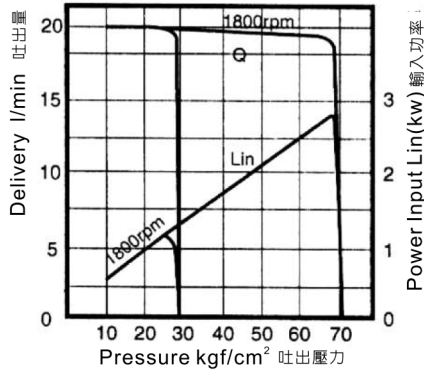

VDC-F20

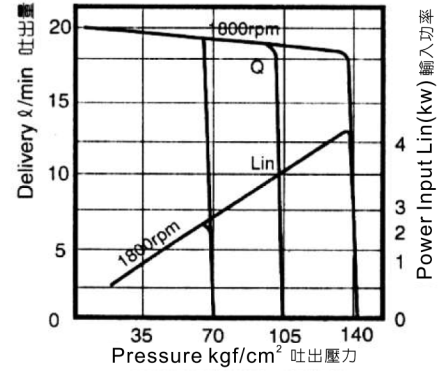

VDC-F25

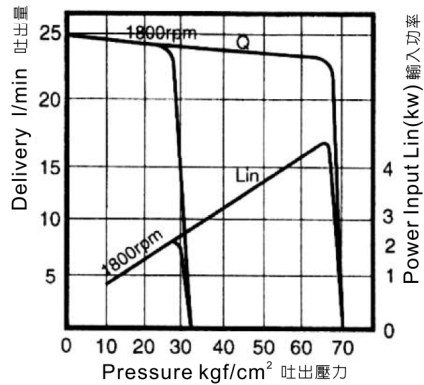

VDC-F25

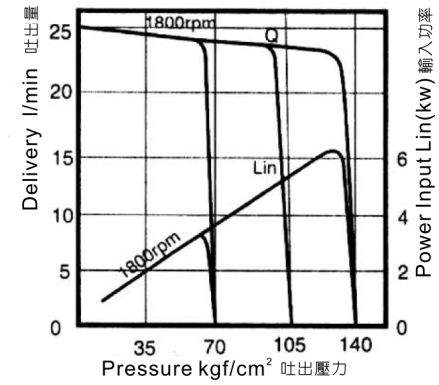

VDC-F30

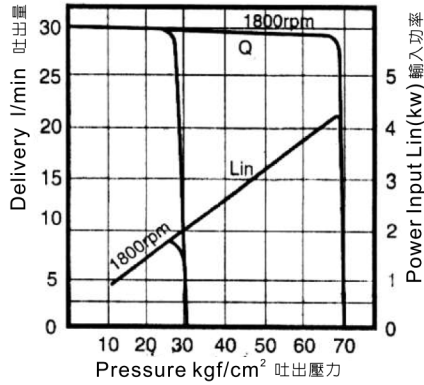

VDC-F30

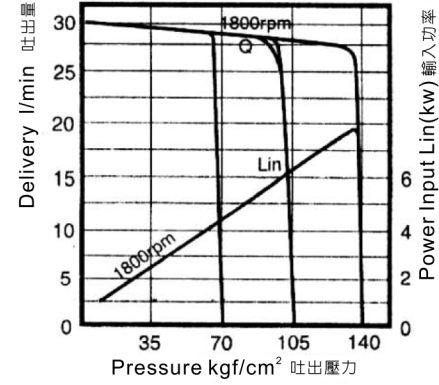

MEDIUM-PRES. VARIABLE DISPLACEMENT VANE PUMPS

中壓變容量輪葉泵

PUMPS

◆ Performance Curves 性能曲線

VDC-F40

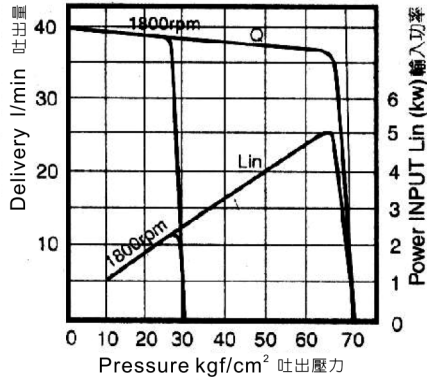

VDC-F40

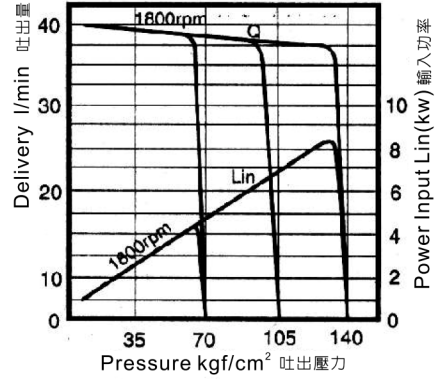

VDC-F54

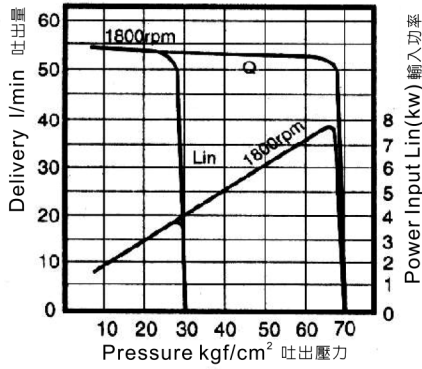

VDC-F54

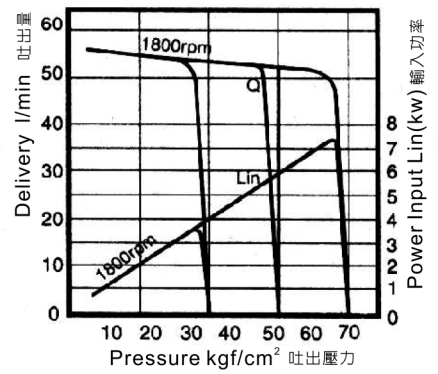

VDC-F70

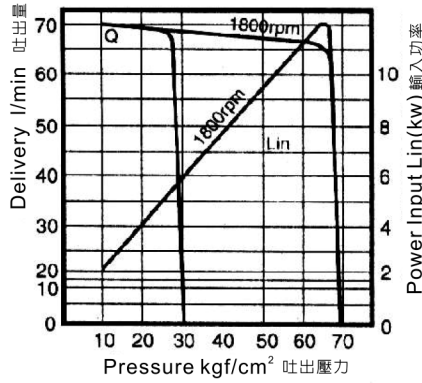

VDC-F70

