

# TL1 系列 SERIES

## TL1-12型 TYPE

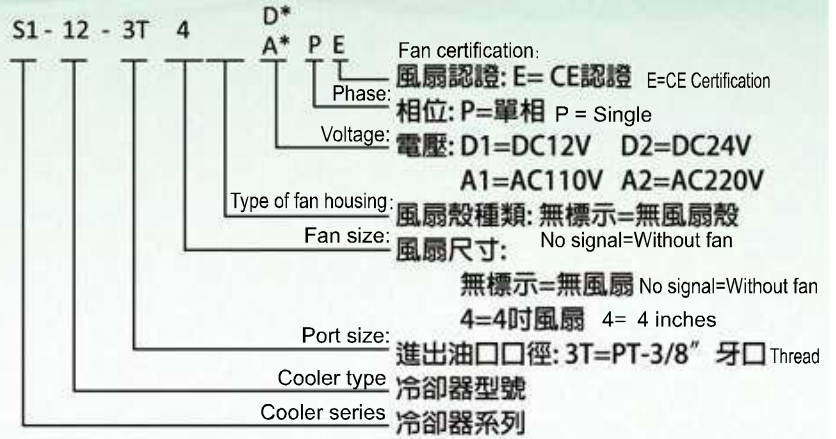

### 外觀尺寸 DIMENSIONS

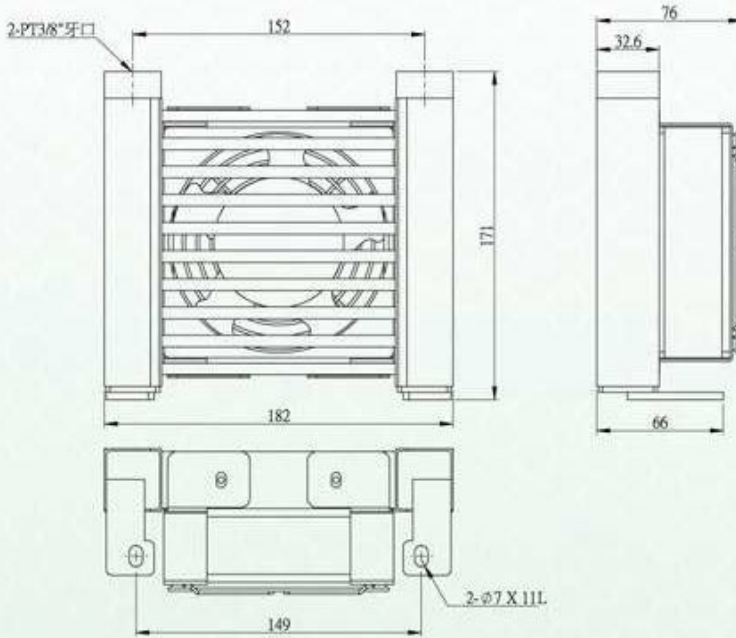

### 性能曲線 PERFORMANCE

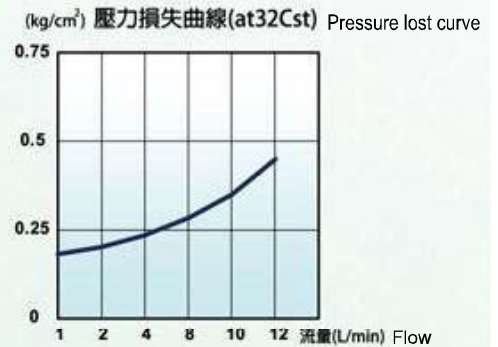
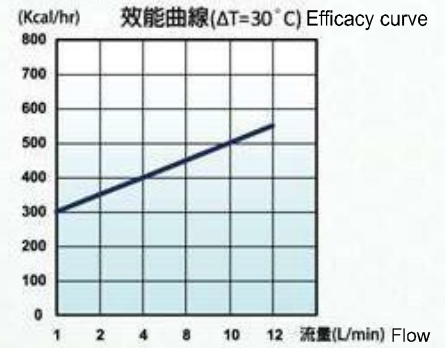

### 產品特性 CHARACTERISTIC

Flow 使用流量 (L/min)	Maximum Antipyretic 最大解熱能力 (Kcal/hr)	Pressure 使用壓力 (Kg/cm <sup>2</sup> )	Voltage 使用電壓 (V, ±10%)	Frequency 使用頻率 (Hz)	Current 使用電流 (A)	Capacity 使用功率 (Watt)	Speed 風扇轉速 (RPM)	Air 空氣量 (m <sup>3</sup> /hr)	Protection 防護等級 (IP)	Noise Value 噪音值 (dB(A))	Fan Certification 風扇認證	Weight 重量 (Kg)
10	- (無風扇)	5	-	-	-	-	-	-	-	-	-	0.7
			DC12	-	0.6	7.2	2,600	187	54	40	CE	1.5
	DC24		-	0.3	7.2	2,600	187	40				
	110		50/60	0.24/0.27	19/23	2,700/3,100	142.8/178.5	45/51				
220	50/60	0.12/0.14	20/24	2,700/3,100	142.8/178.5	45/51						

### 注意事項 NOTICE

- 當冷卻裝置於油壓系統的回油迴路時,為保護冷卻器不因系統中的突波衝擊而破裂,建議加裝旁通卸油迴路為宜。  
When the cooler is applied with hydraulic system, in order not to be broken by surge in the system. Suggest installing the oil reducing device.
- 建議最佳使用方式:另外使用一台獨立小幫浦,單獨抽取油箱內的熱油送至冷卻器冷卻,使其成一獨立循環迴路。  
Best how-to-use: using another pump to draw the oil in the fuel tank into the cooler cooled. Make it an individual recycled circuit.
- 以上規格內容如有變更,依實際產品標示為準。  
If the data sheets above changed, based on actual products.
- 以上規格內容如有特殊需求,請與本公司聯絡。  
If you have any special inquiry of this product, please feel free to contact with us.