

TL2 系列 SERIES

TL2-40型 TYPE

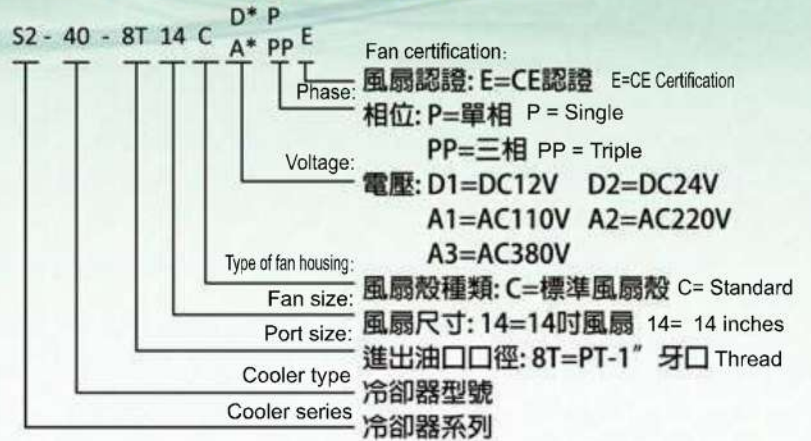

外觀尺寸 DIMENSIONS

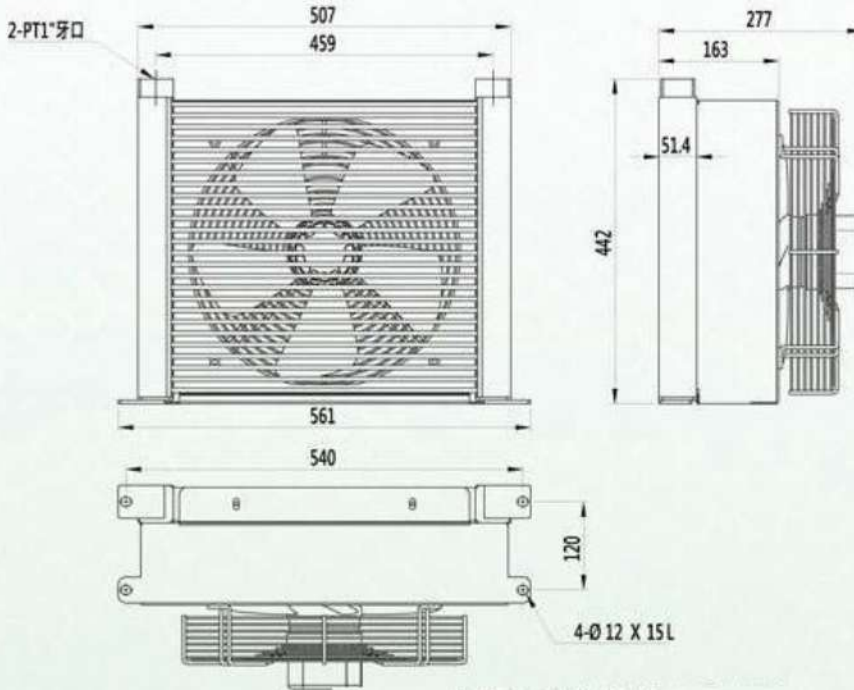

性能曲線 PERFORMANCE

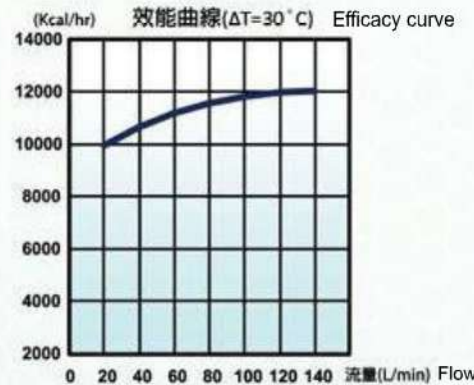

產品特性 CHARACTERISTIC

Flow 使用流量 (L/min)	Maximum Antipyretic 最大解熱能力 (Kcal/hr)	Pressure 使用壓力 (Kg/cm ²)	Voltage 使用電壓 (V, ±10%)	Frequency 使用頻率 (Hz)	Current 使用電流 (A)	Capacity 使用功率 (Watt)	Speed 風扇轉速 (RPM, ±5%)	Air 空氣量 (m ³ /hr)	Protection 防護等級 (IP)	Noise Value 噪音值 (dB(A))	Fan Certification 風扇認證	Weight 重量 (Kg)
110	12,000	15	DC12	-	4.5	54	2,495	1,360	54	70.6	CE	12.5
			DC24	-	2.5	30	2,272	1,097		74.3		
			110	50/60	1.36/1.63	150/180	1,380/1,550	3,170/3,420		62/65		15.3
			220	50/60	0.80/0.70	150/180	1,380/1,550	3,170/3,420		62/65		
			380	50/60	0.40/0.47	150/180	1,380/1,550	3,170/3,420		62/65		

注意事項 NOTICE

- 當冷卻裝置於油壓系統的回油迴路時，為保護冷卻器不因系統中的突波衝擊而破裂，建議加裝旁通卸油迴路為宜。
When the cooler is applied with hydraulic system, in order not to be broken by surge in the system, suggest installing the oil reducing device.
- 建議最佳使用方式：另外使用一台獨立小幫浦，單獨抽取油箱內的熱油送至冷卻器冷卻，使其成一獨立循環迴路。
Best how-to-use: using another pump to draw the oil in the fuel tank into the cooler cooled. Make it an individual recycled circuit.
- 以上規格內容如有變更，依實際產品標示為準。
If the data sheets above changed, based on actual products.
- 以上規格內容如有特殊需求，請與本公司聯絡。
If you have any special inquiry of this product, please feel free to contact with us.