

# TL4 系列 SERIES

## TL4-63型 TYPE

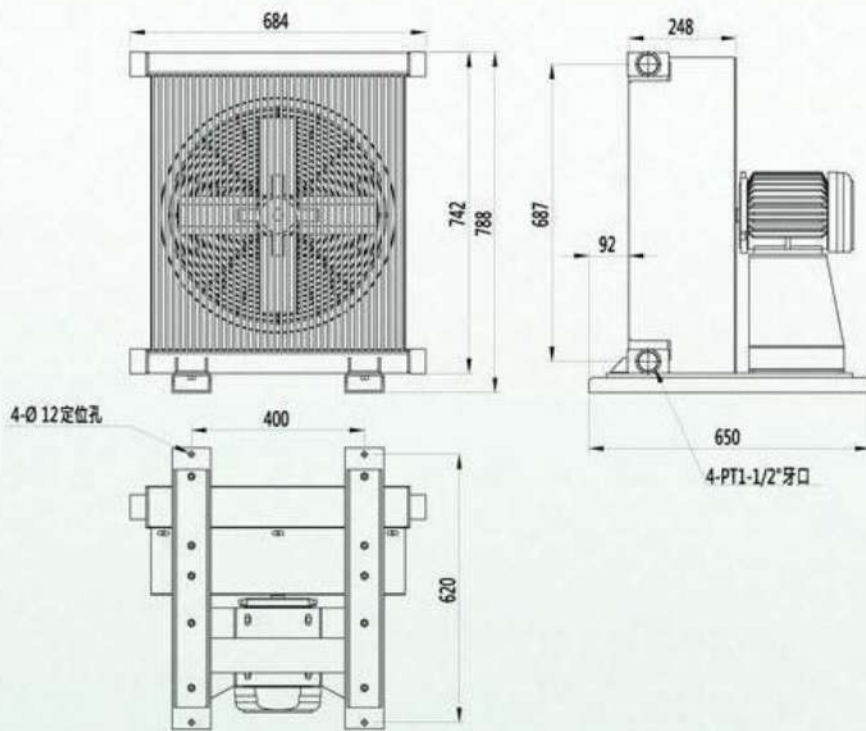

### 外觀尺寸 DIMENSIONS



### 性能曲線 PERFORMANCE

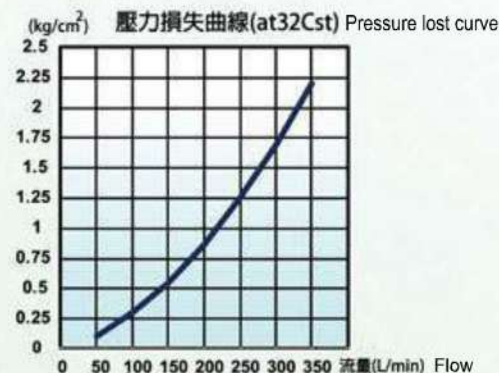
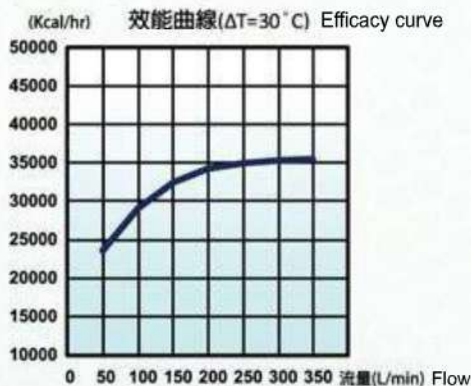

### 產品特性 CHARACTERISTIC

Flow 使用流量 (L/min)	Maximum Antipyretic 最大解熱能力 (Kcal/hr)	Pressure 使用壓力 (Kg/cm <sup>2</sup> )	Voltage 使用電壓 (V, ±10%)	Frequency 使用頻率 (Hz)	Current 使用電流 (A)	Capacity 使用功率 (Kw)	Speed 風扇轉速 (RPM, ±5%)	Air 空氣量 (m <sup>3</sup> /hr)	Protection 防護等級 (IP)	Noise Value 噪音值 (dB(A))	Fan Certification 風扇認證	Weight 重量 (Kg)
300	35,000	20	220	60	5.7	1.25	1,720	7,600	55	78	CE	52.0
			380	60	3.3	1.25	1,720	7,600				

### 注意事項 NOTICE

- 當冷卻裝置於油壓系統的回油迴路時，為保護冷卻器不因系統中的突波衝擊而破裂，建議加裝旁通卸油迴路為宜。  
When the cooler is applied with hydraulic system, in order not to be broken by surge in the system. Suggest installing the oil reducing device.
- 建議最佳使用方式：另外使用一台獨立小幫浦，單獨抽取油箱內的熱油送至冷卻器冷卻，使其成一獨立循環迴路。  
Best how-to-use: using another pump to draw the oil in the fuel tank into the cooler cooled. Make it an individual recycled circuit.
- 以上規格內容如有變更，依實際產品標示為準。  
If the data sheets above changed, based on actual products.
- 以上規格內容如有特殊需求，請與本公司聯絡。  
If you have any special inquiry of this product, please feel free to contact with us.